

Not to scale

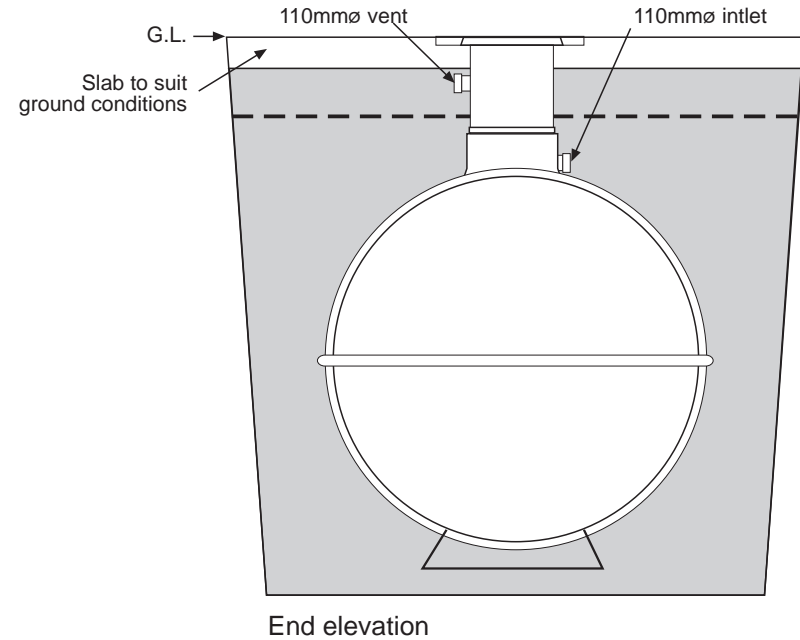
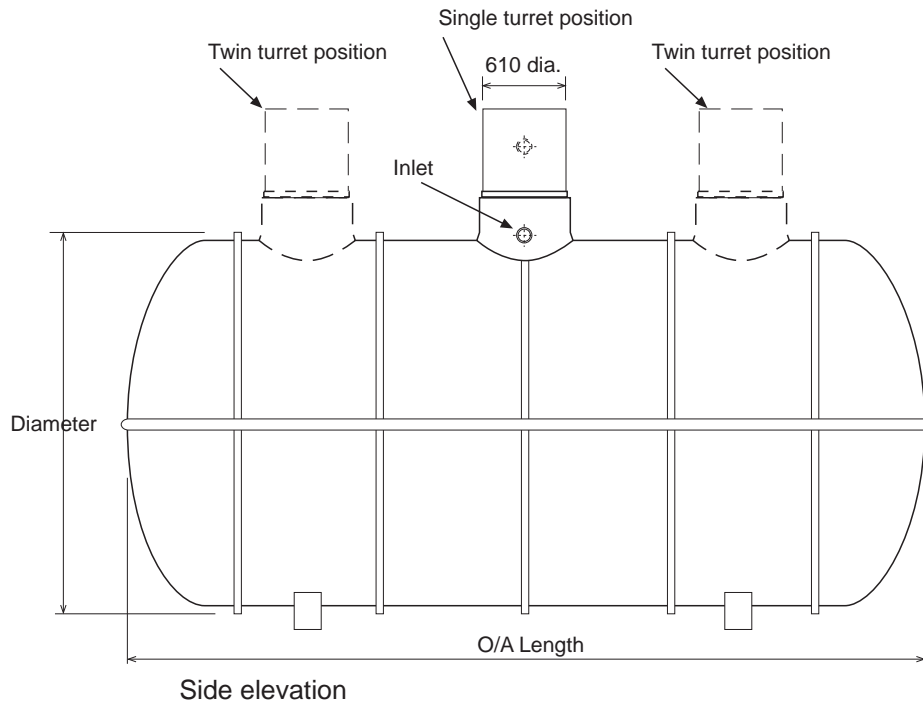

Refer to installation guide

Capacity Litres	Diameter mm	O/A Length mm	
2800	1250	2750	
3800	1250	3500	
4500	1500	2750	
6000	1850	3300	
7500	1850	3800	
9000	1850	4250	single turret
12000	1850	5500	
18000	2600*	4100	
25000	2600*	5500	
30000	2600*	6550	
36000	2600*	7760	
40000	2600*	8580	
45000	2600*	9600	
50000	2600*	10650	two turrets
54000	2600*	11450	
60000	2600*	12650	

* No feet on tank



Acorn Environmental Systems Ltd,
Somerset Bridge, Bridgwater,
Somerset. TA6 6LL
Tel: 01278 439325
Fax: 01278 439324
E-mail: sales@acornsystems.com
Web: www.acornsystems.com

Drawing Title:

SEALED CESSPOOLS

All dimensions are in mm

Scale: NTS

Revision Details:

A	Tank dimensions - Aug '02
B	Turret positions - June '03
C	Tank sizes - Oct '05

Drawing No.

GA99-115c

Date:

June 2003

Drawn by: Artwork