

Not to scale

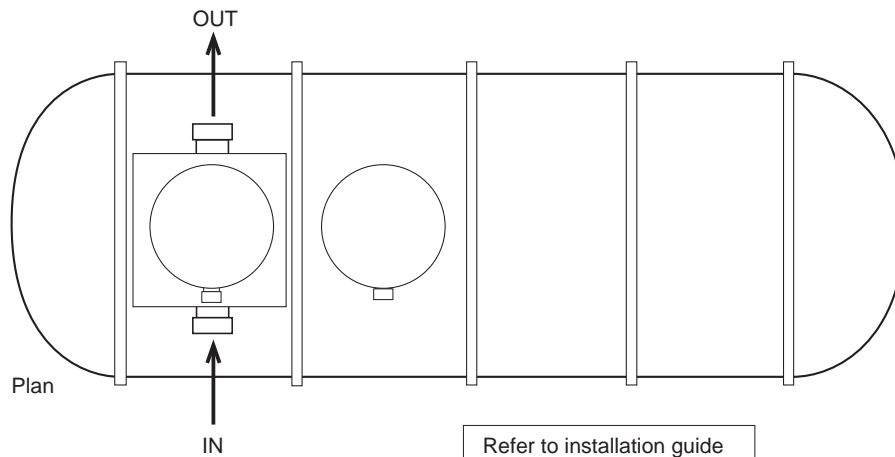

Model No.	Nominal size (NS)	Area drained (m <sup>2</sup> )	Silt capacity	O/A length	Dim A (mm)	Dim B (mm)	Dia (mm)
NSB3/1	3	1667	300	2350	1000	900	1000
NSB4.5/1	4.5	2500	450	2480	1000	900	1000
NSB6/1	6	3333	600	3230	1000	900	1000
NSB8/1	8	4444	800	3250	1250	1150	1200
NSB10/1	10	5556	1000	3800	1250	1150	1200
NSB12/1	12	6667	1200	4500	1250	1150	1200
NSB15/1	15	8333	1500	2800	1800	1700	1850
NSB18/1	18	10000	1800	3250	1800	1700	1850
NSB20/1	20	11111	2000	3600	1800	1700	1850
NSB25/1	25	13889	2500	4500	1800	1700	1850
NSB30/1	30	16667	3000	5100	1800	1700	1850
NSB35/1	35	19444	3500	6700	1800	1700	1850
NSB45/1	45	25000	4500	4100	2500	2400	2600*
NSB60/1	60	33333	6000	5544	2500	2400	2600*
NSB70/1	70	38889	7000	6550	2500	2400	2600*
NSB100/1	100	55556	10000	8580	2500	2400	2600*

\* No feet on tank

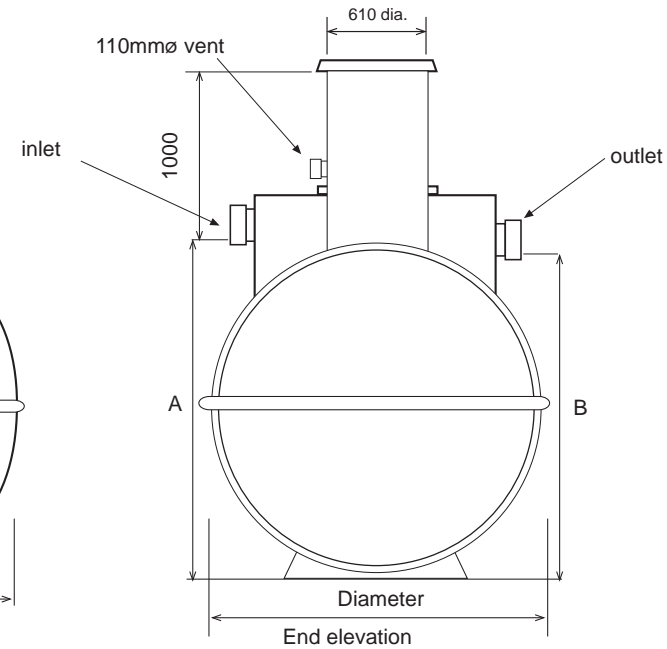
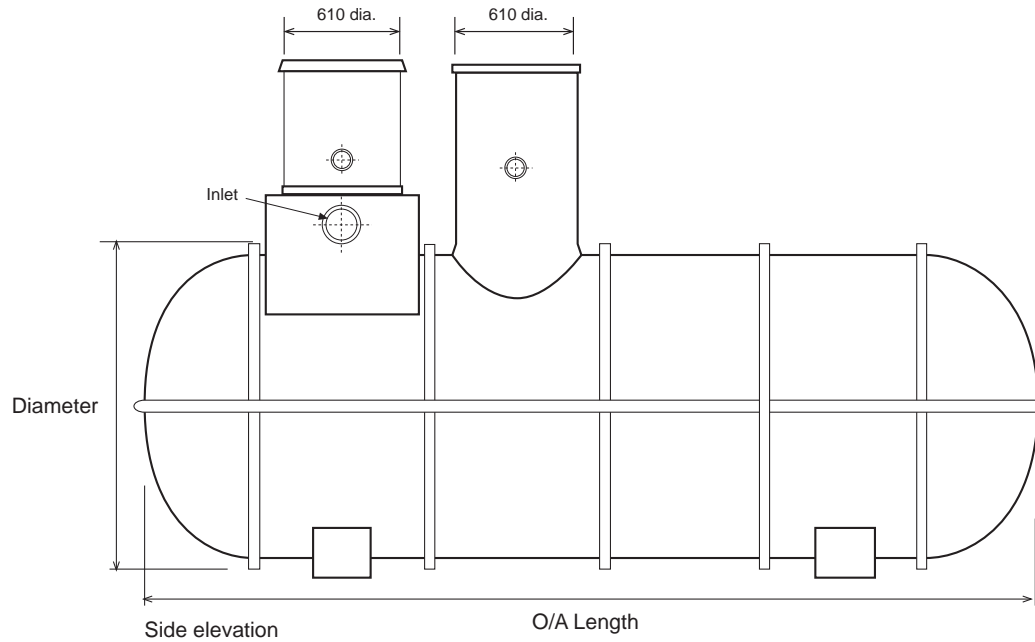

Acorn Environmental Systems Ltd,  
Somerset Bridge, Bridgwater,  
Somerset.TA6 6LL  
Tel: 01278 439325  
Fax: 01278 439324  
E-mail: sales@acornsystems.com  
Web: www.acornsystems.com

Drawing Title:

**Bypass separator**

Revision Details:

<b>A</b>	Dimension amends
<b>B</b>	Dimension amends
<b>C</b>	Minor amends

Drawing No.

**GA03-131C**

Date:

**October 2003**

All dimensions are in mm

Scale: NTS

Drawn by: Artwork